

T500AmkII

Features

- Pure magnesium diaphragm having superior internal loss and less unpleasant sound inherent in metal material realizes the super high frequency reproduction.
- Stronger magnetic circuit using two pieces of $\varnothing 40\text{mm}$ alnico magnets.
- High rigidity Silver-Copper alloy wire is used for the voice coil, and $\varnothing 1.4\text{mm}$ of the same material wire is used for internal connections.
- Newly designed horn with new cutoff frequency is made of ultra-precision cut solid brass.
- Copper terminal & coated plate/pole realize the super-low distortion current.



Specifications

Impedance	: 8 Ω
Reproduction Frequency Response	: 4 kHz - 45kHz
S.P.L.	: 110 dB/W(m)
Music Power	: 50 W
Cutoff Frequency	: 3.5 kHz
Recommended Cross-over Frequency	: more than 7kHz (12dB/Oct.)
Magnet Weight	: 480 g / 1.05 lb
Net Weight	: 5,000 g / 11.0 lb

Frequency Response / Impedance

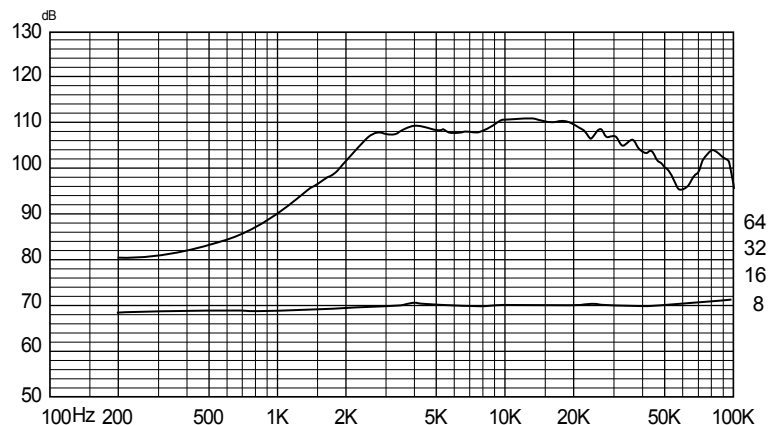

Dimensions & Mounting Information

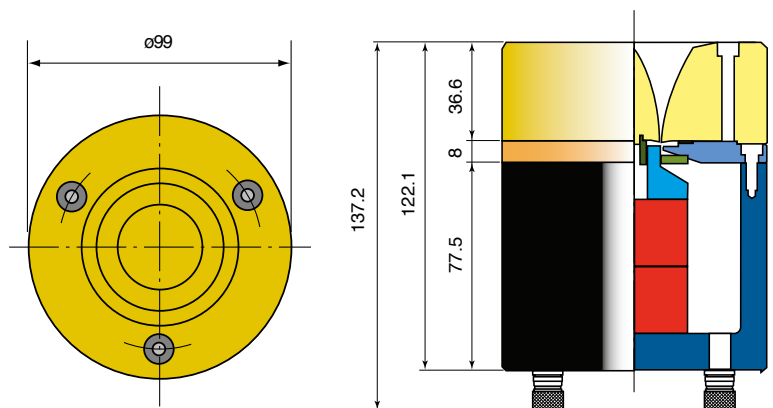

Overall Diameter	: 99 mm / 3.9 in
Depth	: 137.2 mm / 5.4 in